

D A T A S H E E T

MCC450R ROTARY COLLATOR

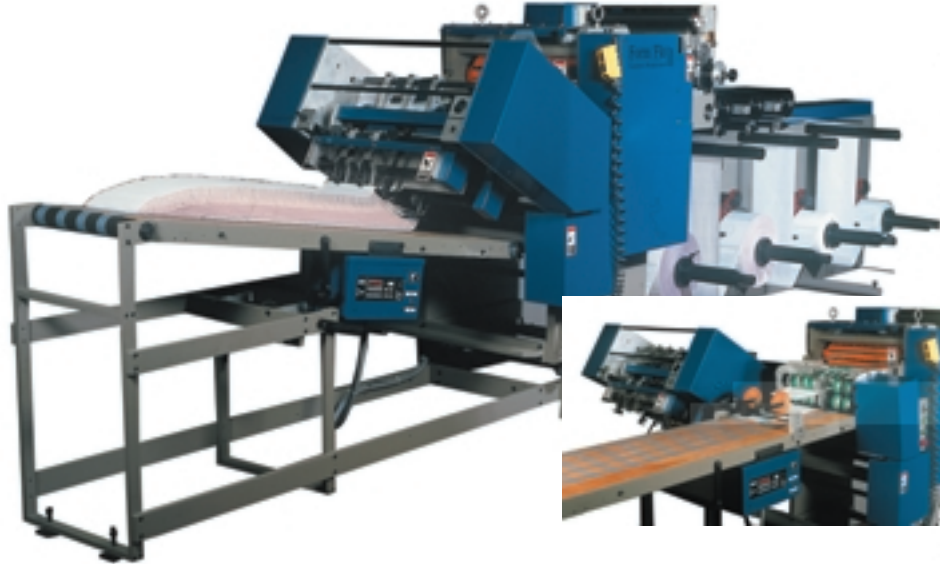

DESCRIPTION:

The MCC450R is a full-featured Rotary Collator with 450 f.p.m. productivity. It has a production speed of 450 f.p.m. and is capable of both unit set and / or continuous processing and features a self-storing folder. Changeover from unit set to continuous can be accomplished in less than ten minutes.

BASIC FEATURES:

- Maximum Web Width: 18"
- Rated Speed: 450 FPM
- Minimum Web Width: 3"
- Paper Weight: 10 lb. Bond – 110 lb. Index (38 g / m² - 199 g / m²)
- Available Fold Sizes: 5-1/2" – 17"
- Available Cross Perf or cutoff Cylinder Sizes: 14" – 28"
- Available Number Repeats: 17 – 28"

BASIC EQUIPMENT:

- Four Station 28" Diameter Unwinds
- Four 17" Circumference Pin Drums
- F600 Processing Section With Infeed and Outfeed Pintractors
- One Down Only Cutoff and Perf Head (Specify Size)
- Lower Anvil Insert
- Dual Size Crimp Lock Unit
- 450 Slide-Away Folder (8-1/2" & 11" Change Gears)
- 360° Running Adjustment Gear Box for folder
- Cut Set Batch Delivery -
- Common Adjustable Speed Creeper Delivery Table
- Electronic Counter With Batch Separation
- 5 H.P. Drive Motor
- Control Console With Remote Jog System

OPTIONS:

- Two Station Addition with Pin Drums
- Gap-out cutoff head
- Linear Perf Unit
- Cross Perf Unit
- Electrical Hoist For Head Changes
- "Roll Caddy" Roll Lift and Transport
- 17" – 28" Variable Size Numbering Unit
- Line or Programmable Glue System
- Cross Web Glue System
- Tape Fastening System
- 18" Diameter Carbon Roll Unwinds
- Spare Parts Package
- C.E. Guarding
- Web Width of 20" – 26"

Technical specifications subject to change.

FORM NUMBER MCC450R - 05/03

© Copyright 2000 Form Flo Equipment Manufacturers, Inc.

Form Flo
Equipment Manufacturers

3154 N. 34th Dr. * Phoenix, AZ 85017
Phone: 602.272.3200 * FAX: 602.272.3509

MCC450R ROTARY COLLATOR

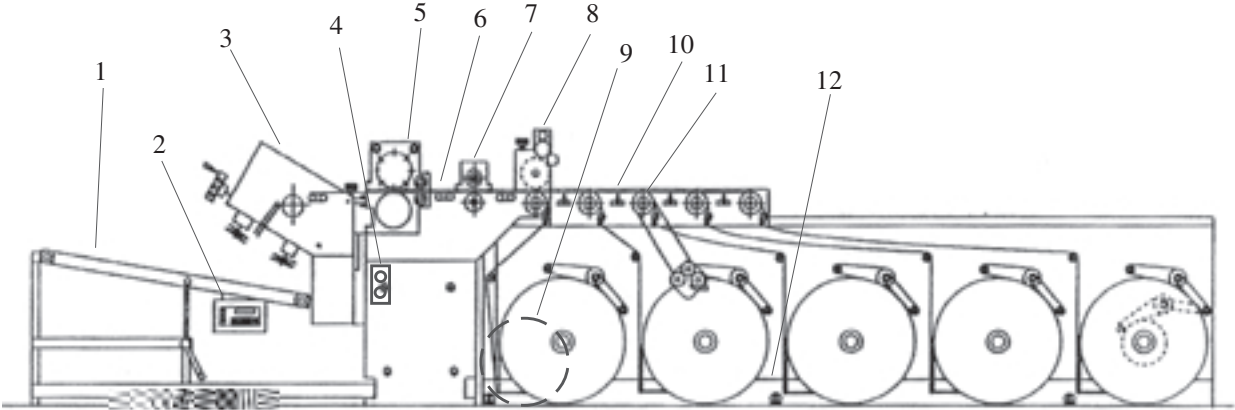

(Optional)

(optional)