

CONTENTS

ACCESSORIES

Ashton Punch & Dies	6-2	Paper Drills	6-14
ATF Punch & Dies	6-2	PB-9	6-5
ATFStyleHolder	6-4	Pioneer The Stroboscope	6-5
Autographic	6-15	Programmable Glue Systems	6-11
Bostitch	6-15	Quick Change Perf/Slitter	6-4
CameronStyleHolder	6-4	Quick Change Conv. Kit	6-4
Carbon Trimmer	6-5	Quick Change GIB	6-16
Cold Glue Applications	6-10	Quick Release Gib Bars	6-8
Collator Cutoff Heads	6-16	Roll-Master	6-9
Core Cutters	6-16	Rubber Strips	6-10
Core Stripper	6-5	Schriber Style Holder	6-4
Crash Numbering/Imprinting	6-16	SchriberQuick Change Holder	6-4
DGStyle Holder	6-4	Slitter and Perf Holders	6-4
Dot glue strips	6-10	Slitter/Perf Holder Parts	6-4
Fastening Systems	6-15	Soft Anvil diecutting	6-6
File hole Punth & Dies	6-2	Special Punches	6-3
Glue systems	6-11	Spinnit Paper Drills	6-14
Hit Skip Blades	6-7	Split ImprintShells	6-8
Hit Skip rings	6-7	Stanley Bostitch	6-15
Horton	6-6	Stitchers	6-15
LASSCO	6-14	Stroboscope	6-5
Line Hole P/D Rings	6-2	Tamarack Pattern Glue	6-10
Line Pattern glue strips	6-10	Tamarack Pip Strips	6-10
Maratnon P/D Rings	6-3	The Shooter	6-13
Marathon Rings	6-3	The UltimateCounter/Tabber	6-13
Nale MICR Encoders	6-15	TrimBlower	6-5

6

ACCESSORIES

NOTES

**Line Hole PUNCH AND DIE RINGS
(SPLITTYPE)**

Prices are same for Western Gear, Schriber, Diddle-Glaser, Hamilton

14"	Single Row Line Hole	\$858.00
14"	Double Row Line Hole	\$1,001.00
17"	Single Row Line Hole	\$924.00
17"	Double Row Line Hole	\$1,067.00
21"	Single Row Line Hole	\$968.00
21"	Double Row Line Hole	\$1,149.50
22"	Single Row Line Hole	\$1,017.50
22"	Double Row Line Hole	\$1,270.50
24"	Single Row Line Hole	\$1,111.00
24"	Double Row Line Hole	\$1,380.00
25.5"	Single Row Line Hole	\$1,232.00
25.5"	Double Row Line Hole	\$1,529.00
28"	Single Row Line Hole	\$1,375.00
28"	Double Row Line Hole	\$1,672.00

FILE HOLE PUNCH & DIE FLANGES (SPLIT RINGS)

14" Single Row	3 Around	\$825.00
14" Single Row	2 & 4 Around	\$825.00
14" Double Row		\$1,243.00
17" Single Row	2 & 4 Around	\$869.00
17" Single Row	3 Around	\$869.00
17" Double Row		\$1,353.00
21" Single Row	2 & 4 Around	\$940.50
21" Single Row	3 Around	\$940.50
21" Double Row		\$1,463.00
22" Single Row	2 & 4 Around	\$1,001.00
22" Single Row	3 & 6 Around	\$1,001.00
22" Double Row		\$1,639.00
24" Single Row	2 & 4 Around	\$1,056.00
24" Single Row	3 & 6 Around	\$1,056.00
24" Double Row		\$1,749.00
25.5" Single Row	2 & 4 Around	\$1,140.00
25.5" Single Row	3 Around	\$1,140.00
25.5" Double Row		\$1,848.00
28" Single Row	2 & 4 Around	\$1,078.50
28" Single Row	3 & 6 Around	\$1,078.50
28" Double Row		\$2,051.50

***HAMILTON, ASHTON & OTHERS USING CLAMPS
CALL FOR PRICING***

MARATHON PUNCH AND DIE RINGS FOR BUSINESS FORMS PRESSES

MARATHON DELIVERS LONG LIFE PUNCHING



MARATHON RINGS ARE GUARANTEED TO *SAVE* you *TIME* AND *MONEY*

AVAILABLE IN SIZES FROM 17" TO 33" CIRCUMFERENCE ALL WITH SEALED BEARINGS FOR MAINTENANCE FREE SERVICE.

MARATHON RINGS ARE PRICED FROM: \$1,995⁰⁰
CALL FOR MORE INFORMATION



ALL RINGS INCLUDE ONE SET OF PUNCHES AND DIES



PRICING FROM: \$995⁰⁰
CALL FOR MORE INFORMATION



SPECIAL PUNCHES AND DIES ARE AVAILABLE
CALL FOR PRICING AND ADDITIONAL INFORMATION

6
A
C
C
E
S
S
O
R
I
E
S

SLITTER AND PERF HOLDERS

ASHTON/SANDEN	\$140.00
STEVENS	120.00
SCHRIBER	120.00
WESTERN GEAR	120.00
DIDDE	130.00
DIDDE (MCM)	140.00
ATF	130.00
CAMERON (DOVE TALE)	140.00
TAIYO	130.00



**DG
STYLE HOLDER**



**CAMERON
STYLE HOLDER**



QUICK CHANGE PERF AND SLITTER HOLDERS

ASHTON/SANDEN	\$165.00
STEVENS	145.00
SCHRIBER	145.00
WESTERN GEAR	139.00
DIDDE	155.00
DIDDE (MCM)	165.00
ATF	155.00
CAMERON (DOVETAIL)	165.00

QUICK CHANGE CONVERSION KIT \$95.00

PLEASE NOTE: WE CAN ALSO INTERCHANGE VIRTUALLY ANY STYLE WHEEL WITH ANY STYLE HOLDER. PLEASE SPECIFY WHEN ORDERING

**SCHRIBER
QUICK CHANGE
STYLE HOLDER**



SLITTER/PERF HOLDER REPLACEMENT PARTS

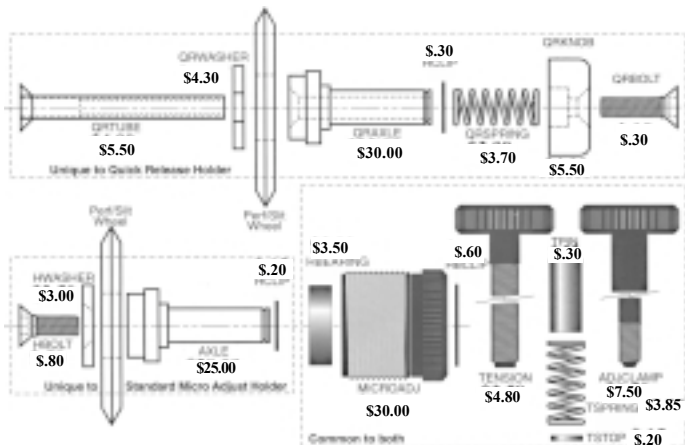

CORE STRIPPER

Designed for the Printing Industry
To meet your salvage requirements

- * Front Loading
- * Cantilevered Style Arbor
- * Larger Models Available
- * Hydraulic Cylinder
- * Positive Action
- * * Safety Engineered

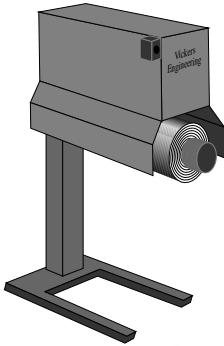

<u>Specifications</u>	<u>18" Hyd.</u>	<u>32" Hyd.</u>
Max. roll	15"D x 18"	19"D x 32"
Length	40"	50"
Width	32"	38"
Height	6' 7"	6' 8"
Weight	850 lbs.	950 lbs.
Power	220/440, 3 ph	220/440, 3 ph
Control	117 VAC	117 VAC
Operation	Dual palm buttons	Dual palm Buttons
Price	\$6,150.00	\$8,850.00
Spare Blades	\$425.00	\$580.00

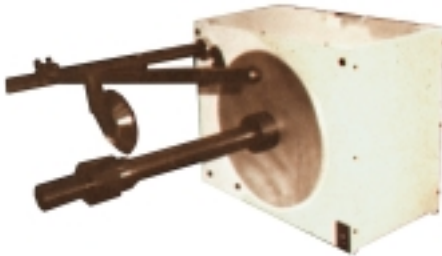

**FormFlo
Equipment Mfg.
Carbon Trimmer
Part Number -- ZCT010000
Priced From \$2,455.00**

PIONEER *THE STROBOSCOPE*

FOR ALL PRESSES MODEL DS-303

- SPEED: 60 TO 30,000
- TOTAL WEIGHT: 10 LBS.
- POWER: 110 VAC
- FLASH TUBE LIFE: 6 x 106
- ONLY \$775.00



TRIM BLOWER

PB-9-9" (Aluminum)

SPB-9-9" (Steel)

(Both models have 5" outlet, direct drive motors rated @ 380 CFM, 115 - 230/60/1 or 230 - 460/60/3)

ONLY \$700.00

OTHER MODELS AVAILABLE ON REQUEST



SOFT ANVIL DIE CUTTING

- * Fits on file punch shaft
- * Split ring construction
- * Replaceable steel rule die
- * Anvil has replaceable polyurethane blanket
- * Fast and easy to install
- * Saves time and money

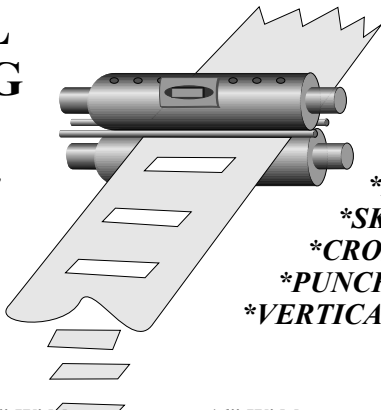

- *WINDOWS
- *I.D. CARDS
- *SKIP SLITS
- *CROSS PERF
- *PUNCH PERF
- *VERTICAL PERF

<u>Press Circ.</u>	<u>12" Width</u>	<u>16" Width</u>	<u>17 - 22" Width</u>
14"-17"	\$4,125. ⁰⁰	\$4,590. ⁰⁰	\$4,956. ⁰⁰
<u>PressCirc.</u>	<u>12"Width</u>	<u>19" -22" Width</u>	<u>34"Width</u>
20",21"&22"	\$4,893. ⁰⁰	\$6,492. ⁰⁰	\$7,950. ⁰⁰
<u>PressCirc.</u>	<u>14"Width</u>	<u>19"-22" Width</u>	<u>26"Width</u>
28"	\$5,490. ⁰⁰	\$7,350. ⁰⁰	\$8,570. ⁰⁰

*All Systems Include: Anvil Cylinder, Spate Anvil Cylinder, Universal Cylinder
Spare Anvil Cover, Anvil Cover Bonding Fixture, 2 Qts. Cover Adhesive
Also available for 23", 24", 25.5" & 26" press. All prices are less dies.*

FORM FLO WEST MASTER SERIES HIT SKIP BLADES

360 DEG. X .020 THIN BLADES TO FIT THE FOLLOWING HIT SKIP REELS
DAVID K HART / CIRCUIT
ECONOMY MACHINE & TOOL

<u>SIZE</u>	<u>PERF QTY</u>			<u>SLITTER</u>		<u>QTY</u>
	<u>2-5</u>	<u>6-9</u>	<u>10+</u>	<u>2-5</u>	<u>6-9</u>	<u>10+</u>
14"	40.75	35.75	32.50	36.50	30.50	28.75
17"	42.00	36.75	33.50	37.50	32.00	30.25
20",21",22"	45.00	39.50	35.75	40.00	33.50	31.75
24"	48.25	42.00	38.00	42.75	35.75	33.75
25 1/2"	49.25	43.75	39.50	44.50	38.00	35.75
28"	49.50	44.00	39.75	44.75	38.25	36.00

On 22" for economy machine and tool type only, specify if for DG or Schriber.

Reduce Your Inventory, By Cutting The Segments To The Size You Need

Three blade minimum except for first - time trial.

Quantity discount based on blades of same size and teeth.

Available teeth/inch: 4.5.6.8.10.12.14.16

with ties of .015,.020,.025,.031,.040,.045,.062 as specified (+/- .002).

Combination perf/slit patterns available. 1-time pattern charge of \$50.00 may apply.

Add \$.50 Per 30 Degree on 30 Tooth Blades.

HIT SKIP RINGS AND BLADES

Perforating, Slitting or Combinations done in the punch section of your press at **FULL PRESS SPEED**. This system offers new opportunities in forms design by running in registration with the print.

Split Shell Construction for Easy Mounting and Optional Replaceable Inner Wear Band on Slit Rings

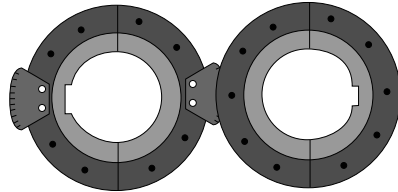

HIT SKIP REELS

<u>Size</u>	<u>EACH SET</u>		<u>TWO OR MORE</u>	
	<u>Standard</u>	<u>Optional</u>	<u>Standard</u>	<u>Optional</u>
14"	\$699.00	\$765.00	\$645.00	\$708.00
17"	725.00	818.00	677.00	750.00
20-21-22"	795.00	890.00	677.00	820.00
24-25-25.5"	902.00	995.00	842.00	938.00
26"	955.00	1,015.00	888.00	958.00
28"	968.00	1,030.00	900.00	983.00

Optional - refers to optional inner wear ring
Field Replaceable inner wear rings are \$75.00 each
Rings & blades interchangeable w/Cir Cut & Harris

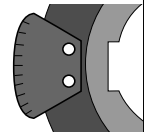
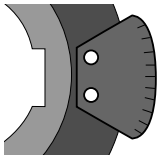

HIT SKIP BLADES

<u>Size</u>	<u>Qty.</u>	<u>PERF BLADE</u>					<u>SLITTER BLADE</u>				
		<u>180</u>	<u>120</u>	<u>90</u>	<u>60</u>	<u>30</u>	<u>180</u>	<u>120</u>	<u>90</u>	<u>60</u>	<u>30</u>
14	1-9	34.50	22.75	19.50	13.00	10.25	29.50	20.25	16.50	11.75	9.75
	10+	29.00	20.00	16.00	11.25	8.50	24.75	17.25	14.50	10.00	7.75
17	1-9	37.25	26.00	20.25	14.25	11.00	32.25	24.00	17.25	13.00	10.00
	10+	31.50	21.75	17.25	12.50	9.25	27.25	19.00	15.25	11.00	8.25
20, 21,	1-9	39.25	27.75	22.00	16.50	12.00	34.50	25.00	19.50	13.50	10.25
22	10+	35.25	24.75	19.50	14.50	10.50	30.50	21.50	17.00	12.25	9.25
24, 25,	1-9	42.25	29.50	23.25	19.75	13.00	36.25	26.00	20.25	16.25	11.75
25.5	10+	37.50	26.25	20.75	17.75	11.50	32.50	22.75	18.50	15.50	10.00
26, 28	1-9	46.00	32.50	24.75	21.50	14.00	40.00	27.75	21.75	20.00	12.25
	10+	41.00	29.00	21.50	19.00	12.50	35.75	25.00	20.25	17.50	11.25

Add \$2.00/piece to cut to inch lengths. For combination perf/slit patterns, add a one time pattern charge of \$50.00. Available teeth per inch: 4,5,6,8,10,12,14,16,18 Please specify tie (.030 - .032 standard). Segments of the same circumference and teeth may be mixed for quantity discount. A minimum order of \$75.00 is required.

(For 30 TPI x .015 TIE, Add \$.50 per 30Degree)

QUICK RELEASE GIB BARS

LEADERS IN THE INDUSTRY

* SIMPLICITY * PRODUCTIVITY * PROFITABLE *

SAVE 5 to 15 minutes on every blade change * SMOOTH, Simple, Quick and Easy

* Changes ALL Blades (Perf - Cutting - Micro - Score)

INCREASED BLADE LIFE * Same Depth setting every time

Increase Efficiency and Profitability



QTY	UNDER 25"	25" - 33" LONG
1-9	\$830.00	\$1,090. ⁰⁰
10-19	800.00	1,060. ⁰⁰
20+	750.00	990. ⁰⁰
INSTALLATION KIT		\$55. ⁰⁰
TOOL SET		\$80. ⁰⁰

Form Flo West Static Eliminator

It's Simple * Easy to Use * and Best of all It works and needs no constant upkeep and maintenance

Only \$30.⁰⁰ a Roll (72'/Box)

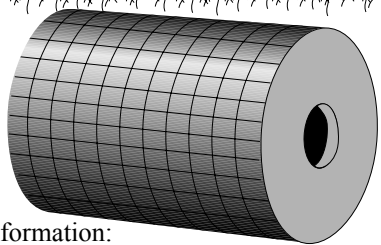

Form Flo West Split Imprint Shells

Available for "ALL" Presses

To Order we will need the following information:

1. Circumference _____
2. Length _____
3. Shaft diameter _____
4. Key Size _____
5. Undercut _____
6. Material Thickness _____
7. Scribed every 1/2" _____
8. Marked around _____

Size	6" Length	Over 6" Length
14"	\$452.00	\$54.00/Inch
15" - 17"	\$516.00	\$72.00
21" - 22"	\$658.00	\$85.00
23" - 24"	\$772.00	\$98.00
25" - 28"	\$928.00	\$110.00

Continue to next page: **ROLL-MASTER BY FORM FLO WEST**

6
A
C
C
E
S
S
O
R
I
E
S